

产品描述:

TM3B020I60D4V1 是一款 600V/20A 三相全桥智能功率模块，内置了低损耗沟槽栅场截止型 IGBT 和 FRD，内部集成了自举二极管 BSD，简化了客户的 PCB 设计。内部集成温度输出 VOT 功能用于检测模块内部的温度。集成欠压保护，过流保护，过温保护。

Description

TM3B020I60D4V1 is a 600V/20A three-phase full-bridge intelligent power module (IPM). The module integrates low-loss trench-gate field-stop IGBTs and fast recovery diodes (FRD), as well as bootstrap diodes (BSD) to significantly simplify customer PCB design. It features a built-in temperature output function (VOT) for real-time internal temperature monitoring, and provides multiple protection functions including under-voltage protection (UVP), over-current protection (OCP) and over-temperature protection (OTP), which comprehensively improves system reliability.

主要特点:
MAIN FUNCTION AND RATING

- 集成 6 颗低损耗 IGBT (600V/20A)
- Integrated 6 low-loss IGBTs (600V/20A)
- 集成高压栅极驱动电路 (HVIC)
- Integrated high voltage gate drive circuit (HVIC)
- 内置欠压保护、过温保护、过流保护及温度输出功能
- Built-in under voltage protection and over temperature, over current protection and temperature output
- 内置带限流电阻的快速恢复自举二极管
- Built-in fast recovery bootstrap diode with current limiting resistor
- 绝缘等级: 1500Vrms / 分钟
- Insulation class 1500Vrms / min
- 高可靠性、热稳定性好、参数一致性佳
- High reliability and thermal stability, good parameter consistency
- 内置温度输出功能
- Built-in temperature output

应用:
APPLICATION

- 变频空调压缩机驱动
- Inverter air-conditioning compressor drive
- 工业伺服变频器
- Industrial servo converter
- 大功率风机、水泵
- High power inverter's fan and water pump
- 电机驱动器
- Motor driver

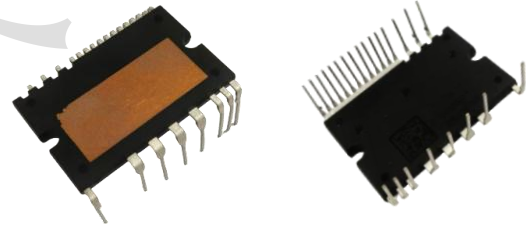
封装/Package: DIP24
订购信息 Ordering Information

产品型号 Part Number	封装形式 Package	包装方式 Shipping
TM3B020I60D4V1	DIP24	条管 Tube

内部等效电路/管脚说明

Internal Equivalent Circuit/Pin Configuration



图 1：内部等效电路

Fig1: Internal Equivalent Circuit

图 2：引脚定义图

Fig2: Final Equivalent Circuit

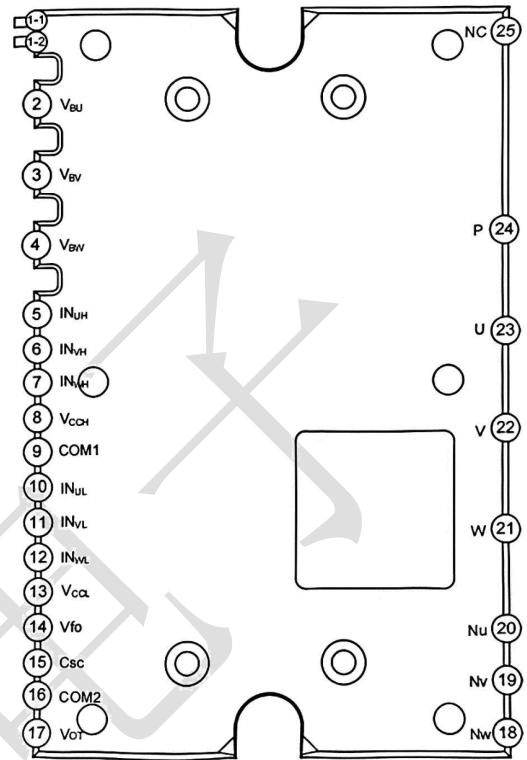
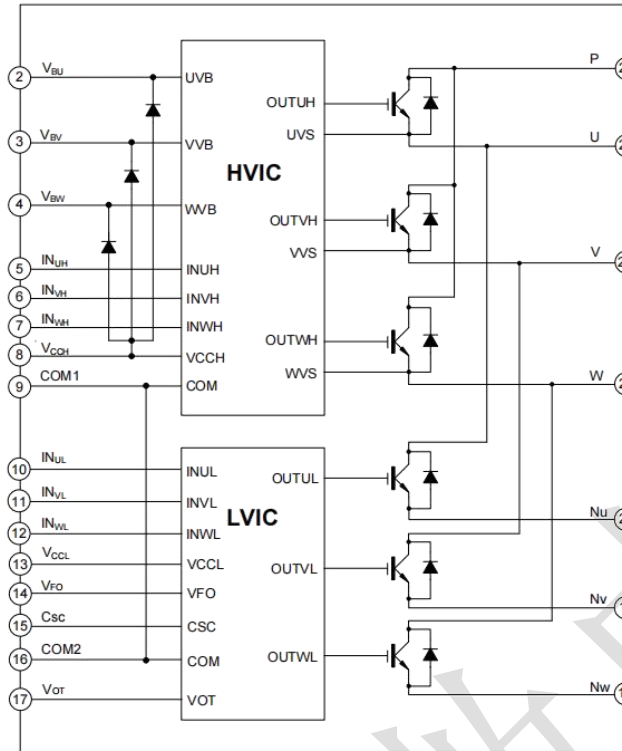
管脚定义/Pin Descriptions

管脚编号 Pin Number	管脚名称 Pin Name	管脚描述 Pin Descriptions
(1-1)	COM	内部公共接地端 Internal common ground terminal
(1-2)	V_{CC}	内部电源端，悬空（不连接） Internal power terminal, No Connection
2	V_{BU}	U 相高端悬浮电源 U-phase high side floating IC supply voltage
3	V_{BV}	V 相高端悬浮电源 V-phase high side floating IC supply voltage
4	V_{BW}	W 相高端悬浮电源 W-phase high side floating IC supply voltage
5	IN_{UH}	U 相高端栅极驱动输入 U-phase high side gate driver input
6	IN_{VH}	V 相高端栅极驱动输入 V-phase high side gate driver input
7	IN_{WH}	W 相高端栅极驱动输入 W-phase high side gate driver input
8	V_{CCH}	高端栅极驱动供电电压 High side gate drive supply voltage

9	COM1	模块公共接地端 Module common ground
10	IN _{UL}	U 相低端栅极驱动输入 U-phase low side gate driver input
11	IN _{VL}	V 相低端栅极驱动输入 V-phase low side gate driver input
12	IN _{WL}	W 相低端栅极驱动输入 W-phase low side gate driver input
13	V _{CCL}	低端栅极驱动供电电压 low side gate drive supply voltage
14	V _{FO}	故障输出 Fault Output
15	C _{SC}	外接电容端，用于短路电流检测输入与低通滤波 External capacitor, used for short-circuit current detection input and low-pass filtering
16	COM2	模块公共接地端 Module common ground
17	V _{OT}	温度输出端 Temperature output terminal
18	N _W	W 相直流负极端 W-phase DC negative terminal
19	N _V	V 相直流负极端 V-phase DC negative terminal
20	N _U	U 相直流负极端 U-phase DC negative terminal
21	W	W 相输出端 Output for W Phase
22	V	V 相输出端 Output for V Phase
23	U	U 相输出端 Output for U Phase
24	P	直流母线正端输入 Positive DC-Link Input
25	NC	悬空（不连接） No Connection

最大额定值 ($T_c = 25^\circ\text{C}$, 除非特殊说明)

Maximum Ratings ($T_c = 25^\circ\text{C}$ Unless Otherwise Specified)

逆变部分/Inverter Part

符号 Symbol	参数 Parameter	条件 Condition	额定值 Ratings	单位 Unit
V_{PN}	电源电压 Supply Voltage	施加于 P - NU、NV、NW 之间 Applied between P-NU, NV, NW	450	V
$V_{PN}(\text{surge})$	电源电压 (含浪涌) Supply Voltage (Surge)	施加于 P - NU、NV、NW 之间 Applied between P - NU, NV, NW	500	V
V_{CE}	集电极 - 发射极电压 Collector-Emitter Voltage		600	V
I_{CE}	集电极电流 Each IGBT Collector Current	$T_c=25^\circ\text{C}$, $T_j \leq 150^\circ\text{C}$	20	A
I_{CP}	集电极峰值电流 Each IGBT Collector Current (Peak)	$T_c=25^\circ\text{C}$ $T_j \leq 150^\circ\text{C}$	40	A
P_D	芯片功耗 Power dissipation per one chip	$T_c=25^\circ\text{C}$	41	W

控制部分/Control(Protection) Part

符号 Symbol	参数 Parameter	条件 Condition	额定值 Ratings	单位 Unit
V_{CC}	控制电源电压 Control the supply voltage	应用于 V_{CCH} -COM1 COM2, V_{CCL} -COM1 COM2 之间 Applied between VCCH-COM1 COM2, VCCL-COM1 COM2	20	V
V_{BS}	高端控制电压 High-side control voltage	应用于 V_{BU} -U, V_{BV} -V, V_{BW} -W 之间 Applied between V_{BU} -U, V_{BV} -V, V_{BW} -W	20	V
V_{IN}	输入信号电压 Input signal voltage	应用于 IN_{UH} , IN_{VH} , IN_{WH} , IN_{UL} , IN_{VL} , IN_{WL} -COM 之间 Applied between IN_{UH} , IN_{VH} , IN_{WH} , IN_{UL} , IN_{VL} , IN_{WL} -COM	$-0.3 \sim V_{CC} + 0.3$	V
V_{FO}	故障输出电源电压 Fault output supply voltage	应用于 V_{FO} -COM 之间 Applied between V_{FO} -COM	$-0.3 \sim V_{CC} + 0.3$	V
T_J	工作结温范围 Operating junction temperature range		-40 to 150	°C
T_c	工作壳温范围 (结温 $\leq 150^\circ\text{C}$) Working shell temperature range, $T_J \leq 150^\circ\text{C}$		-30 to 100	
T_{STG}	存储温度范围 Storage temperature range		-40 to 125	°C

$R_{\theta_{JCQ}}$	单 IGBT 结 - 壳热阻 Single IGBT thermal resistance, junction-case		3.0	$^{\circ}\text{C}/\text{W}$
$R_{\theta_{JCF}}$	单 FRD 结 - 壳热阻 Single FRD thermal resistance, junction-case		2.4	$^{\circ}\text{C}/\text{W}$
V_{ISO}	绝缘测试电压 Isolation test voltage	1 分钟, 有效值, 频率 60Hz 1min, RMS, $f = 60\text{Hz}$	1500	V_{rms}

备注 1: 功率芯片最高结温为 150°C 。为保证智能功率模块 (IPM) 安全工作, 建议平均结温 $T_J \leq 125^{\circ}\text{C}$ (壳温 $T_C \leq 100^{\circ}\text{C}$ 条件)。

Note 1: The maximum junction temperature of the power chip is 150°C , in order to ensure that IPM can work safely, it is recommended that the average junction temperature $T_J \leq 125^{\circ}\text{C}$ (@ $T_C \leq 100^{\circ}\text{C}$)

推荐工作条件/Recommended Operation Conditions

符号 Symbol	项目 Parameter	条件 Condition	最小值 Min	典型值 Typ	最大值 Max	单位 Unit
V_{PN}	直流母线 P- N 端供电电压 DC link supply voltage of P-N	应用于 P-UN/UV/UW 之间 Applied between P-UN/UV/UW	-	300	400	V
V_{CC}	低端驱动电源电压 Low side supply voltage	应用于 $V_{\text{CCH-COM}}$ 之间 Applied between $V_{\text{CCH-COM}}$	13.2	-	20	V
V_{BS}	高端悬浮电源电压 (VB 对 VS) High side floating supply voltage (VB v.s VS)	应用于 $V_{\text{BU-U}}, V_{\text{BV-V}}, V_{\text{BW-W}}$ 之间 Applied between $V_{\text{BU-U}}, V_{\text{BV-V}}, V_{\text{BW-W}}$	13.0	-	20	V
F_{PWM}	PWM 载波频率 PWM carrier frequency				20	kHz
DT	高端与低端输入间外部死区时间 External dead time between HIN & LIN		2.0			μS
V_{COM}	VSS- N 之间电压 (含浪涌) Voltage between VSS - N (including surge)		-5		5	V
$PW_{\text{IN(ON)}}$ $PW_{\text{IN(OFF)}}$	最小输入脉冲宽度 Minimum input pulse width		1			μS
dV_{CC}/dt dV_{BS}/dt	控制电源电压变化范围 Control supply variation		-1		1	$\text{V}/\mu\text{S}$

电气特性: (TC = 25°C, 除非特殊说明)

Electrical Characteristics (TC = 25°C Unless Otherwise Specified)

逆变部分/Inverter Part

符号 Symbol	项目 Parameter	条件 Condition	最小值 Min	典型值 Typ	最大值 Max	单位 Unit
VCE (SAT)	集电极与发射极间饱和电压 Collector-emitter saturation voltage	$V_{CC}=V_{BS}=15V, V_{IN}=5V$ $I_C=15A, T_J = 25^\circ C$	-	1.7	2.2	V
VF	FRD 正向导通压降 FRD forward voltage	$V_{IN}=0V, I_F=15A,$ $T_J = 25^\circ C$	-	1.6	2.0	V
ton	开关时间 (高侧) Switching time (high side)	$V_{PN} = 300V,$ $V_{CC}=V_{BS}=15V,$ $I_C = 15A, V_{HLIN,LIN} = 5V,$ 感性负载	-	709	-	ns
tr			-	39	-	ns
toff			-	669	-	ns
tf			-	57	-	ns
trr			-	170	-	ns
ton	开关时间 (低侧) Switching time (low side)	$V_{PN} = 300V, V_{CC} = V_{BS}$ $= 15V,$ $I_C = 15A, V_{HLIN,LIN} = 5V,$ Inductive load	-	843	-	ns
tr			-	114	-	ns
toff			-	697	-	ns
tf			-	44	-	ns
trr			-	192	-	ns
ICES	集电极发射极漏电流 Collector-Emitter Leakage current	$V_{CE}=600V$	-	-	250	uA



图 3. 开关时间的定义
Figure 3. Definition of switching time

控制部分/Control(Protection) Part

符号 Symbol	项目 Parameter	条件 Condition	最小值 Min	典型值 Typ	最大值 Max	单位 Unit
I_{QCC}	控制电源静态电流 (VCC) Quiescent V _{CC} supply current	V _{CC} =15V, V _{IN} =0V	-	-	3.5	mA
I_{QBS}	高端悬浮电源静态电流 (VBS) Quiescent VBS supply current	V _{BS} =15V, V _{IN} =0V	-	75	-	uA
V_{FOH}	故障输出电压 Fault output voltage	V _{SC} =0V, VF 电路: 10kΩ 电阻上拉至 5v VSC=0V, VF Circuit: 10kΩ to 5V Pull-up	4.9	-	-	V
V_{FOL}		V _{SC} =1V, I _{F0} =1mA	-	-	0.9	V
t_{FO}	故障输出脉冲宽度 Fault output pulse width	故障持续 Fault duration	40	-	-	us
$V_{SC(ref)}$	短路保护触发电压 Short-circuit protection trigger voltage	V _{CC} =15V	0.42	0.46	0.51	V
OT_t	过温保护 Over temperature protection	LVIC 温度 LVIC temperature	100	120	140	° C
OT_{rh}	过温保护滞回 Over temperature protection hysteresis	LVIC 温度滞回特性 LVIC temperature Hysteresis	-	10	-	° C
V_{OT}	温度输出 (见图 4) Temperature output (Figure 4)	LVIC 温度=25°C LVIC Temperature=25°C	0.88	1.13	1.39	V
		LVIC 温度=90°C LVIC Temperature=90°C	2.63	2.77	2.91	V
UV_{Dt}	低端欠压保护 (见图 7) Low-side under voltage protection (Figure 7)	V _{CC} 触发电压 VCC senses voltage	10	11	12	V
UV_{Dr}		V _{CC} 复位电压 VCC reset voltage	9	10	11	V
UV_{DBt}	高端欠压保护 (见图 8) High-side under voltage protection (Figure 8)	V _{BS} 触发电压 VBS senses voltage	10	11	12	V
UV_{DBr}		V _{BS} 复位电压 VBS reset voltage	9	10	11	V
V_{IH}	导通阈值电压 On-threshold voltage	逻辑高 Logic high	-	-	2.5	V
V_{IL}	关断阈值电压 Shutdown threshold voltage	逻辑低 Logic low	0.8	-	-	V

自举二极管部分/Bootstrap diode section

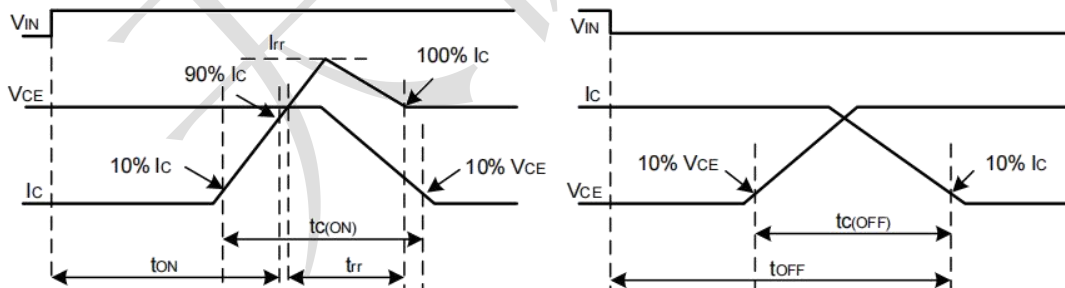
符号 Symbol	项目 Parameter	条件 Condition	最小值 Min	典型值 Typ	最大值 Max	单位 Unit
V_F	正向电压 Forward voltage	$I_F=10\text{mA}$, $TC=25^\circ\text{C}$	-	2.5	4.0	V
t_{rr}	反向恢复时间 Reverse recovery time	$I_F=10\text{mA}$, $TC=25^\circ\text{C}$	-	50	-	ns

V_{OT}输出曲线/V_{OT} Output Curve



图 4: V_{OT} 温度特性曲线 (典型值)

Figure 4. Temperature Profile of V_{OT} (Typical)

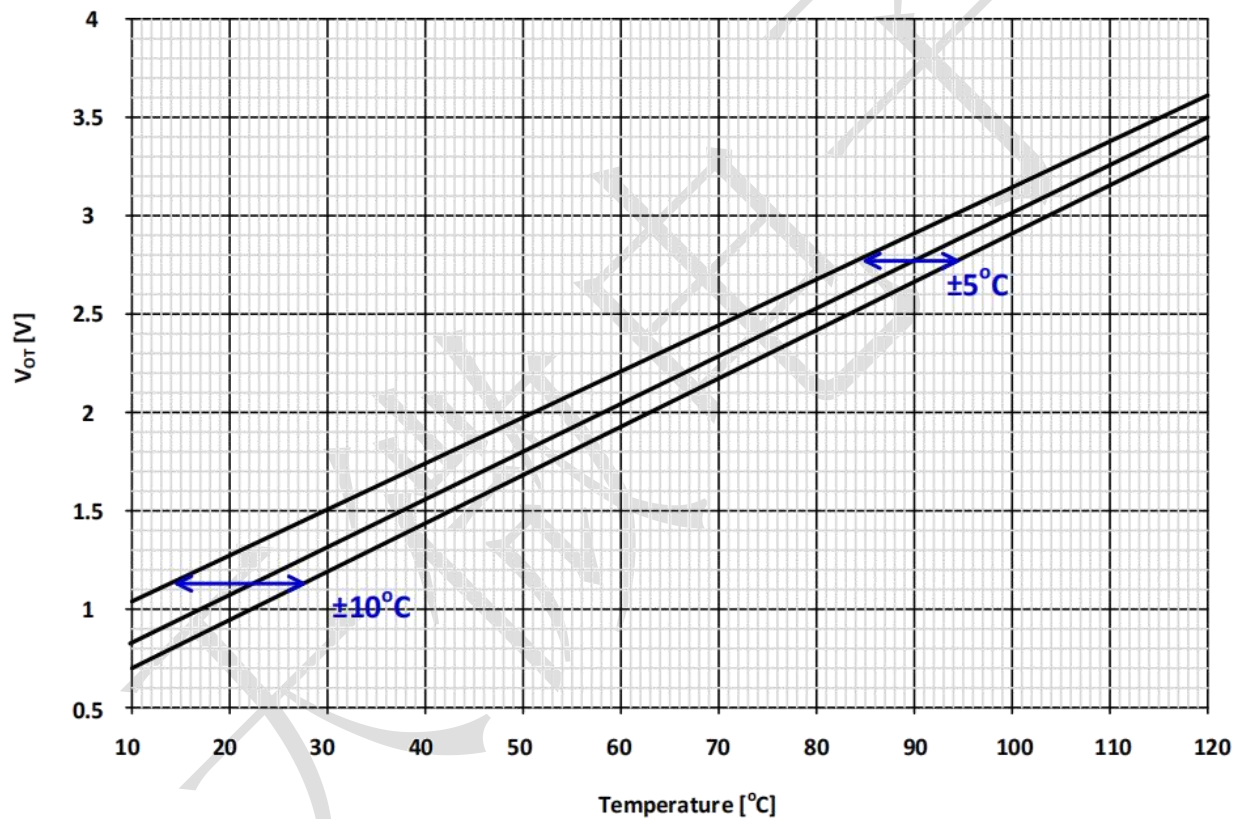

图 5: VOT 输出电路
Figure 5 VOT output circuit

1、若使用温度监测功能，请在 VOT 引脚外接 $5k\Omega$ 电阻，并禁用内部 OTP 功能；若使用内部过温关断功能，则 VOT 引脚保持悬空（不连接）。

If the temperature monitoring function is used, connect $5k\Omega$ to the VOT pin, and ignore the internal OTP function. If the internal over temperature shutdown function is used, keep the VOT pin on (no connection).

2、当 IPM 用于低压控制场景（如 MCU 工作电压为 3.3V）时，温度急剧上升情况下 VOT 输出电压可能高于 3.3V 控制电源电压。低压控制系统建议在控制电源与 VOT 输出信号之间并联钳位二极管，防止过压损坏。

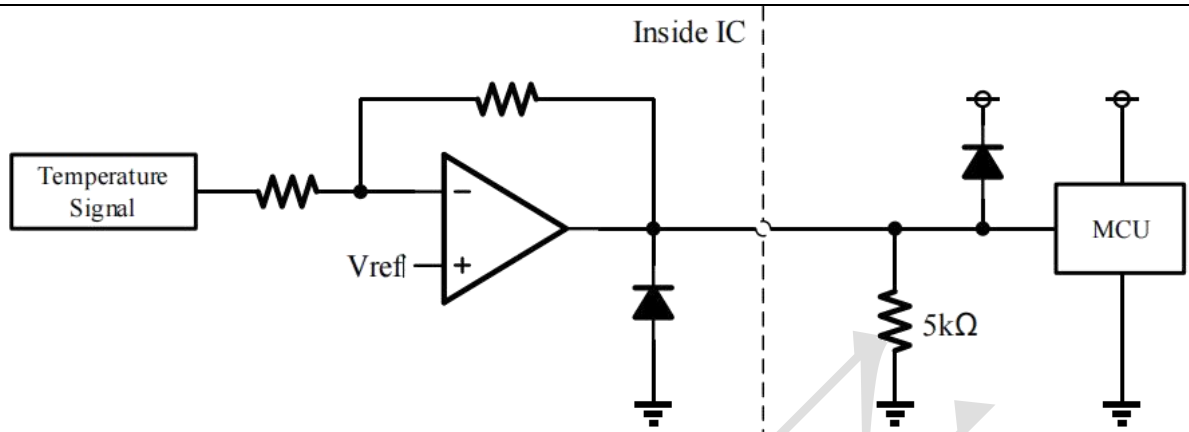
When IPM is applied in low-voltage control (such as MCU working voltage of 3.3V), the output voltage of VOT may be greater than the control supply voltage of 3.3V in the case of a sharp rise in temperature, if the system is used for low-voltage control, it is recommended to connect a clamping diode between the control power supply and the VOT output signal to prevent over voltage damage.



图 6: 短路电流保护 (仅针对下桥臂 / 低端)

Figure 6. Short-circuit current protection (low side only)

t1: 正常工作, 低端输出导通。

t1: Normal operation, Low-Side output.

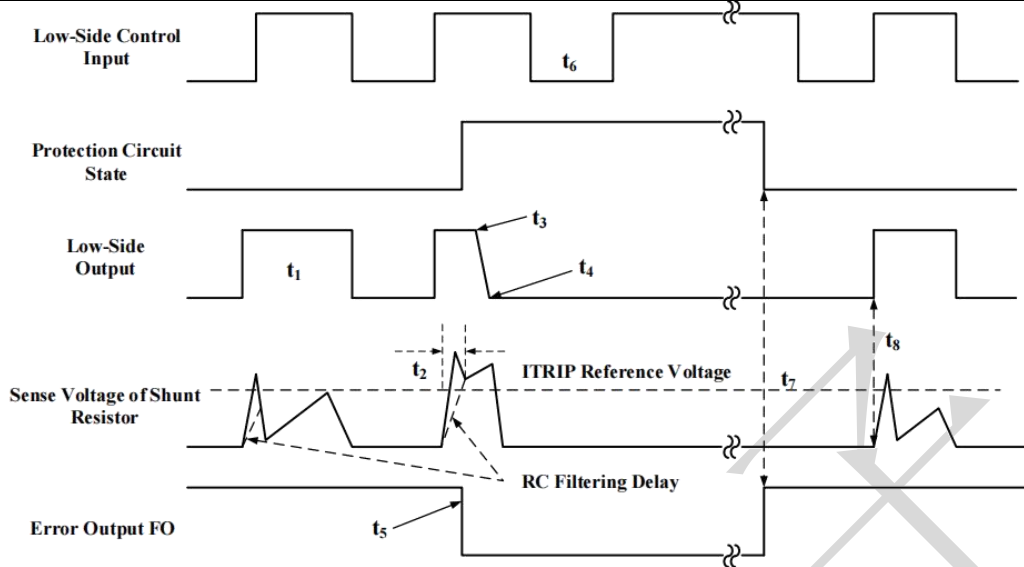
t2: 短路电流检测 (ITRIP 触发)。

(建议设置 RC 时间常数为 $1.5 \sim 2.0 \mu s$, 确保 ITRIP 触发后 IGBT 在 $2.0 \mu s$ 内关断。)

t2: Short circuit current detection (ITRIP trigger).

(It is recommended to set RC time constant $1.5 \sim 2.0 \mu s$ so that IGBT shunt down within $2.0 \mu s$ when ITRIP be triggered.)

t3: 所有低端输出被硬中断。

t3: All low-side outputs are hard interrupted.

t4: 所有低端输出关断。

t4: All low-side outputs turn off.

t5: FO 输出持续时间 $t_{FO} \geq 40 \mu s$ (最小值)。

t5: FO outputs for $t_{FO} = 40 \mu s$ (min).

t6: 输入为低电平, 输出保持关断。

t6: Input is low, outputs turn off.

t7: FO 恢复高电平, 但输出需待输入信号由低变高后方可重新导通。

t7: FO rise to high, but outputs don't turn on until input signal change low to high.

t8: 恢复正常工作, 输出导通。

t8: Normal operation, outputs on.



图 7: 欠压保护 (低端)

Figure 7. Under voltage Protection (Low Side)

- b1: 控制电源电压 V_D 高于欠压复位阈值 U_{VDr} , 在下一个输入波形到来时电路开始工作。
b1: Control supply voltage V_D exceeds under voltage reset level U_{VDr} , and the circuit starts to work when the next input waveform arrives.
- b2: 正常工作: IGBT 导通并输出电流。
b2: Normal operation: IGBT ON and outputs current.
- b3: V_D 电压下降至欠压动作阈值 U_{VDt} 以下。
b3: V_D level drops under voltage trip level (U_{VDt}).
- b4: 无论控制输入状态如何, 所有低端 IGBT 均关断。
b4: All low side IGBTs turn off in spite of control input condition.
- b5: F0 引脚输出故障信号 ($t_{FO} \geq 40 \mu s$, 且在欠压期间持续输出故障信号)。
b5: F0 pin outputs fault signal ($t_{FO} \geq 40\mu s$, and continuously outputs fault signal during under voltage).
- b6: V_D 电压恢复至 U_{VDr} 。
b6: V_D level reaches U_{VDr} .
- b7: 正常工作: IGBT 导通并输出电流
b7: Normal operation: IGBT ON and outputs current.

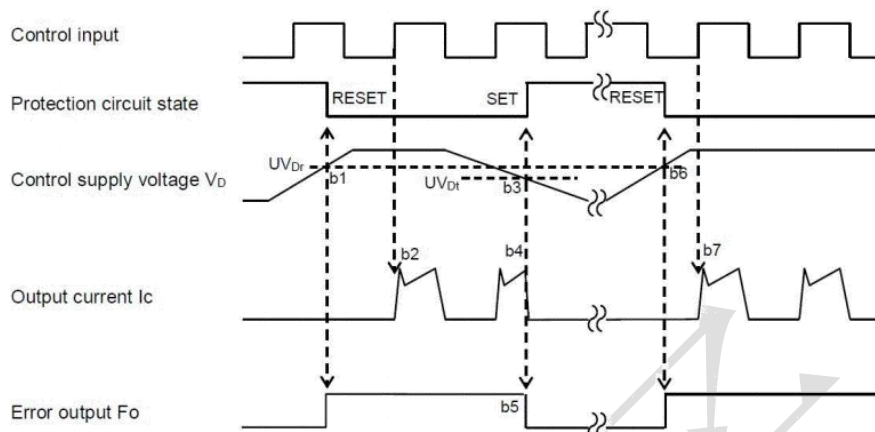

图 8: 欠压保护 (高端)

Figure 8 Under voltage Protection (High Side)

c1: 控制电源电压 V_{DB} 上升至欠压复位阈值 UV_{DBr} , 在下一个输入信号到来时电路开始工作。

c1: Control supply voltage V_{DB} rises to UV_{DBr} , and the circuit starts to work when the next input signal arrives.

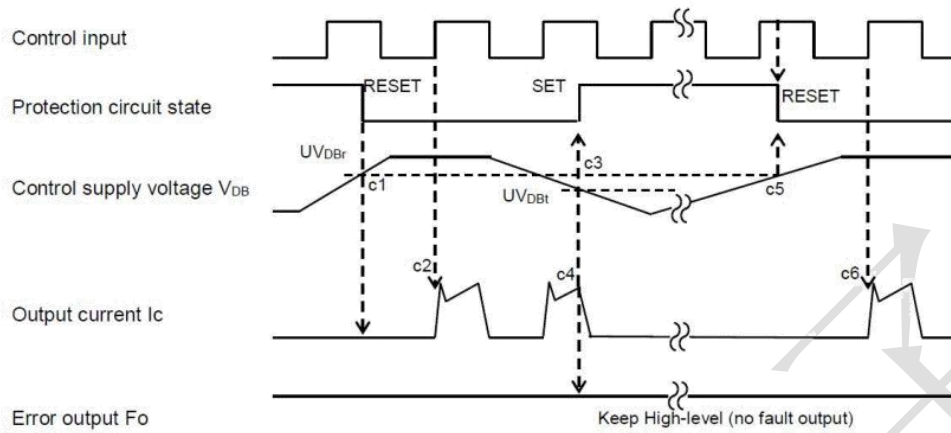
c2: 正常工作: IGBT 导通并输出电流。

c2: Normal operation: IGBT ON and outputs current.

c3: V_{DB} 电压下降至欠压动作阈值 UV_{DBt} 以下。

c3: V_{DB} level drops to under voltage trip level (UV_{DBt}).

c4: 无论输入信号如何, IGBT 均关断, 但无故障信号输出。

c4: No matter what signal input, IGBT is turned off, but there is no fault signal output.

c5: V_{DB} 电压恢复至 UV_{DBr} 。

c5: V_{DB} level reaches UV_{DBr} .

c6: 正常工作: IGBT 导通并输出电流。

c6: Normal operation: IGBT ON and outputs current.



图 9：过温保护（仅低端）

Figure 9. Over temperature protection (low side only)

- d1: 正常工作：IGBT 导通并输出电流。
- d1: Normal operation: IGBT ON and outputs current.
- d2: 低压集成电路（LVIC）温度超过过温保护触发阈值（ OT_t ）。
- d2: LVIC temperature exceeds the over temperature protection trigger level(OT_t).
- d3: 无论控制输入状态如何，所有低端 IGBT 均关断。
- d3: All low side IGBTs are turned off in spite of control input condition.
- d4: 过温期间持续输出故障信号，最小脉冲宽度为 $40\ \mu s$ 。
- d4: Continuously output fault signal during over temperature, and the minimum pulse width is $40\ \mu s$.
- d5: 当温度低于过温保护复位阈值时，LVIC 复位。
- d5: The LVIC will reset when the temperature is lower than the over temperature protection level.
- d6: 当下一个输入控制信号到来时，IGBT 重新导通。
- d6: IGBT turns on when the next input signal control signal comes.

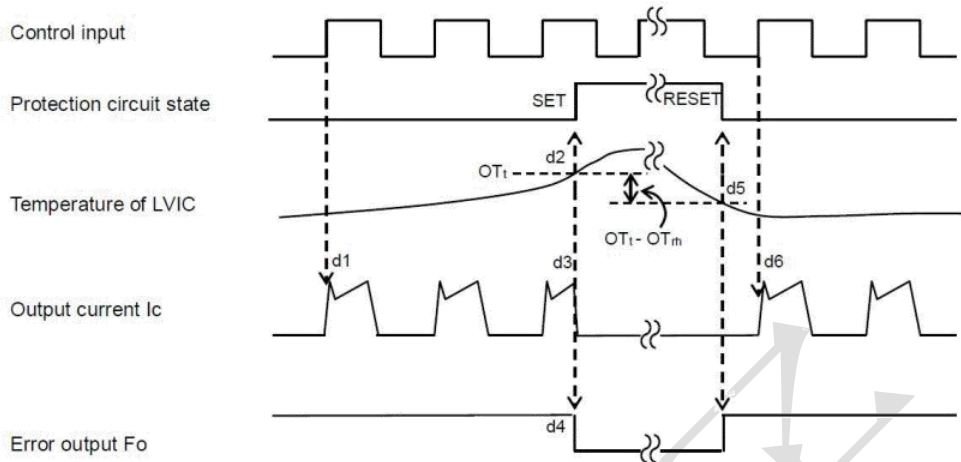

图 10：MCU 输入 / 输出连接电路（推荐方案）

Figure 10. MCU input/output connection circuit (recommended)

注意：各输入端的 RC 耦合电路需根据 PWM 控制方案及 PCB 布局进行适配。IPM 输入信号端内部集成一个 $5k\ \Omega$ 下拉电阻，因此在使用外部滤波电路时，需注意输入端的电压降。

Note: The RC coupling at each input should be adapted to the PWM control scheme and PCB layout. One $5K$ pull-down resistor is built into the IPM input signal section, so pay attention to the voltage drop at the input when using an external filter circuit.

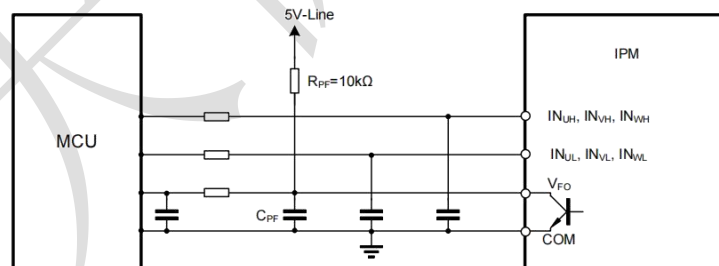

图 11：典型应用原理图

Figure 11. Typical Application Schematic

备注/Remark:

(1) 各输入引脚连线应尽可能短，否则可能引起误动作；

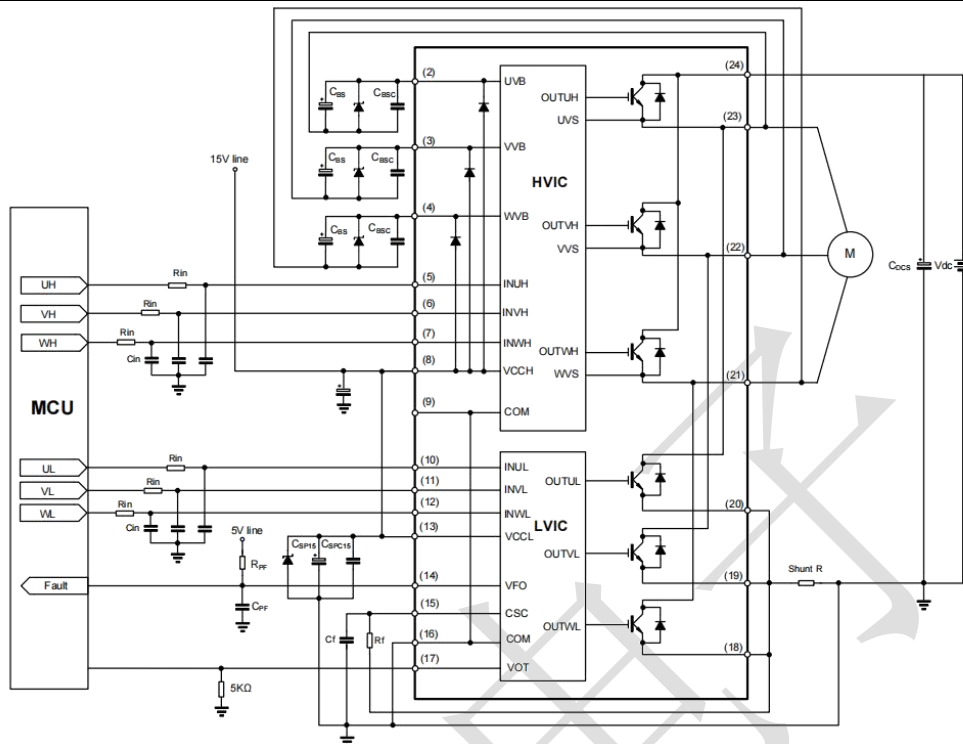
The connection of each input pin should be as short as possible, otherwise it may cause misoperation;

(2) 输入信号为高电平有效，每个 HVIC 通道输入端均接有 5kΩ 下拉电阻；此外，可在输入端增加 RC 滤波电路，以抑制由异常输入引发的浪涌噪声；

The input signal is active high, and a 5 KΩ pull-down resistor is connected to ground at the input of each HVIC channel; In addition, an RC filter circuit can be added at the input to prevent surge noise caused by incorrect input;

(3) 为防止浪涌损坏，建议在 P-N 之间加装高频无感片状电容 (0.1 μF~0.22 μF)，电容连线应尽可能短；

In order to prevent surge damage, it is recommended to add a high-frequency non-inductive flat capacitor (0.1μF ~ 0.22μF) between PNs, and the connection of the capacitor should be made Keep it as short as possible;

(4) 电流检测电阻与 IPM 之间的连线应尽可能短，否则连线电感产生的大幅浪涌电压可能导致器件损坏；

The connection between the current sense resistor and the IPM should be as short as possible, otherwise the large surge voltage generated by the connection inductor may cause damage;

(5) 建议 15V 电源输入端的滤波电容容量至少为自举电容 CBS 的 7 倍；

The filter capacitor at the input of the 15V power supply is recommended to be at least 7 times that of the bootstrap capacitor CBS;

(6) 各外接电容应尽量靠近 IPM 引脚放置；

Each external capacitor should be placed as close as possible to the IPM pin;

(7) VFO 输出为开漏结构，应通过电阻上拉至 5V 电源，使电流 Ifo 约为 1mA；

The VFO output is open and should be pulled up to the 5V supply through the resistor so that the Ifo is 1mA;

(8) 在短路保护电路中，请选择时间常数为 1.5~2.0 μs 的 RF 与 CSC，且 RF、CSC 周边布线应尽可能短。RF 布线应靠近分流电阻。

In the short-circuit protection circuit, please select RF and CSC with time constants in the range of 1.5~2 μs, and the wiring around RF and CSC should be as short as possible. The RF wiring should be close to the shunt resistor.

